

# VON DUPRIN®

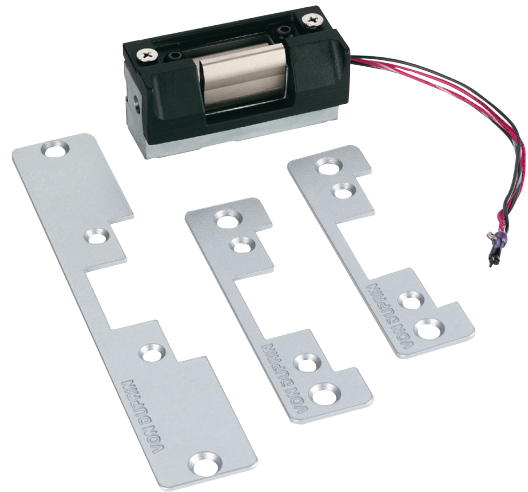

## 5100 Series

Electrical strikes

Von Duprin is the leading manufacturer of premium, heavy-duty electric strikes which are known for their reliability, durability and security. Electric strikes provide remote release of a locked door, allowing the door to be opened without retracting the latchbolt. Remote access enabled through the release of an electric strike lip (sometimes called a keeper or a gate). When the door closes, the bevelled latchbolt rides over the lip and falls into the electric strike pocket.

The Von Duprin 5100 Series electric door strike has been designed to offer flexibility and convenience for locksmiths and security professionals alike. This easy-to-install electric strike was created for medium-duty applications, specifically to control traffic flow through interior and exterior openings in retail and commercial environments.

### Features

- Developed with Von Duprin's high standards and engineering expertise
- Non-handed
- 12 VDC or 24 VDC
- Fall secure (FSE) or fall safe (FS) select ability
- Adjustable strike box for compensation of any door or frame misalignment
- Heavy-duty stainless steel construction
- Tested over 1,000,000 cycles
- 455kg to 680kg holding strength
- 32kg impact strength
- Tamper resistance design

Warranties	
Mechanical	5 years
Electronic	1 year

# Specification guide

## Code prefix

VDE

## Model

5100.....10068

### 1. Code prefix

All codes are prefixed with ..... VDE

### 2. Model

Select the desired model e.g., 5100 ..... VDE100068

## Finish



### ALUM

Aluminium

- The solenoid has four wires, allowing you to configure the strike at the job site so you can use it in either 12 or 24 volt DC applications
- Easily changeable between fail-safe and fail-secure in the field without the need for additional parts
- 3mm horizontally adjustable keeper. This mechanism, allows the installer to adjust the strike where a door and frame are not properly aligned or where weather stripping is causing too much pressure on the strike
- 3 face plates included for hollow metal, wood or aluminium frames
- Retrofit kit
- Fall safe/fail secure

### 5100 Series electric strikes

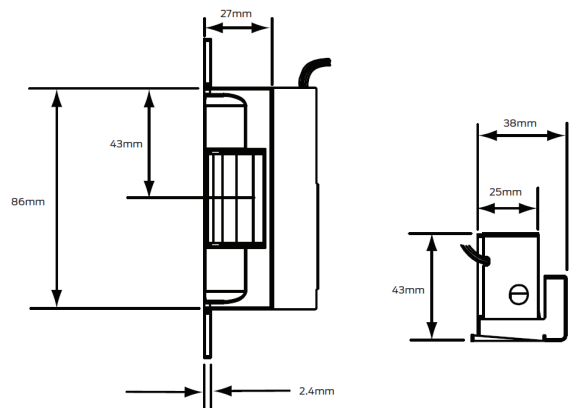
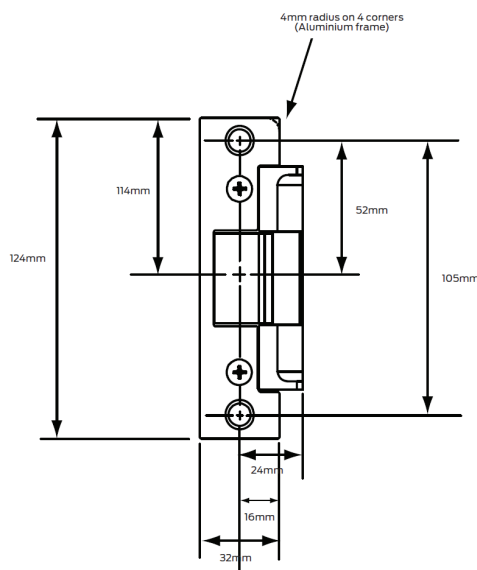
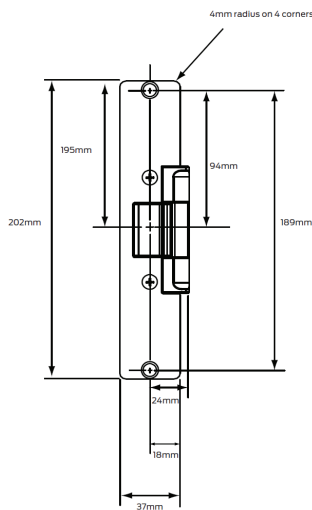

Specifications	12V	24V
Resistance in Ohms±10% @ 21°C	32	128
Power (watts)	4.5	4.5
Current (amps)	.38	.19
Holding strength	454kg	453kg
Impact strength	32kg	32kg